

## Technical Bulletin

Compact MINI range of Gravity Spray Guns  
for spot repairs and small areas



# Table of Contents

<b>Topic</b>	<b>Page</b>
EC Declaration of Conformity.....	3
Part Numbers .....	3
Operational Description .....	3
Kit contents .....	4
Construction Features .....	4
Materials of Construction .....	4
Specifications & Technical Data .....	4
Safety Precautions .....	5
Parts List .....	6
Exploded Parts View .....	7
Installation, Operation, Preventive Maintenance & Cleaning .....	8
Parts Replacement/Maintenance .....	9
A. Servicing Air Valve .....	9
B. Replacing Air Valve .....	10
C. Needle Packing, Fluid Insert, Spreader Valve Assembly .....	11
D. Spray Head Seal .....	12
E. Chart 1 – Air Caps, Chart 2 – Fluid Nozzles & Fluid Needles .....	13
Troubleshooting Possible Problems in Operation .....	14
Accessories .....	16
Warranty.....	16

## EC Declaration of Conformity

We, ITW Finishing UK, Ringwood Rd, Bournemouth, Dorset, BH11 9LH, UK, as the manufacturer of the Spray gun model **Compact MINI**, declare, under our sole responsibility, that the equipment to which this document relates is in conformity with the following standards or other normative documents:

BS EN 292-1 PARTS 1 & 2: 1991, BS EN 1953: 1999; and thereby conform to the protection requirements of Council Directive 98/37/EEC relating to Machinery Safety Directive, and;

EN 13463-1:2001, council Directive 94/9/EC relating to Equipment and Protective Systems intended for use in Potentially Explosive Atmospheres protection level II 2 G X. This product also complies with the requirements of the EPA guidelines, PG6/34.



B. Holt, Vice President  
1st Dec 2008

ITW Finishing Systems and Products reserve the right to modify equipment specification without prior notice.

## Part Numbers

The ordering codes for the Compact MINI Spray Gun are:

COMM-HS1-10 Compact MINI HVLP 1.0  
 COMM-HS1-12 Compact MINI HVLP 1.2  
 COMM-TS1-10 Compact MINI Trans-Tech® 1.0  
 COMM-TS1-12 Compact MINI Trans-Tech® 1.2  
 COMM-RS1-08 Compact MINI Round Spray Trans-Tech® 0.8

## Operational Description

This Compact MINI Spray Gun is a professional quality gun designed with both high volume, low pressure (HVLP) technology or Trans-Tech® technology. HVLP Technology reduces overspray and limits air cap pressure to 0.7 bar (10 psi) (complies with rules issued by SCAQMD and other air quality authorities). Trans-Tech technology, will obtain transfer efficiencies above 65%.

**IMPORTANT:** These Sprayguns are suitable for use with both waterbased and solvent based coating materials. These guns are not designed for use with highly corrosive and/or abrasive materials and if used with such materials it must be expected that the need for cleaning and/or replacement of parts will be increased. If there is any doubt regarding the suitability of a specific material, contact your DeVilbiss Distributor or DeVilbiss direct.

**NOTE:** This gun is not to be used with halogenated hydrocarbon solvents or cleaning agents such as 1,1,1,-Trichloroethane or methylene chloride. These solvents can react with the aluminium components used in this gun and cup. The reaction can become violent and lead to an equipment explosion.

**KIT CONTENTS (ALL MODELS)**

1	Compact MINI Gravity Feed Spraygun
1	Compact MINI Gravity Feed Cup
1	Cup Filter
1	Funnel
1	Spanner (6mm hex and 10mm A/F)

1	Torx/Flat Blade Screwdriver
1	Small Cleaning Brush
1	Large Cleaning Brush
1	Service Bulletin

**CONSTRUCTION FEATURES**

1	Air Cap (nickel plated brass for long durability)
2	Air Cap Retaining Ring (allows easy rotation of air cap)
3	Fluid Nozzle
4	Fluid Needle (grooved stem for easy removal)
5	Fluid Inlet (7/16" – 14 UNC thread) – accepts DeVilbiss SRI cup systems
6	Air Inlet (universal thread, accepts G 1/4 & 1/4 NPS)
7	Self Adjusting Needle Packing (for trouble free operation)
8	Trigger (ergonomic for comfort)
9	Trigger Stud & Screw (easy replacement design)

10	Fan Air Adjustment (stepless regulation for fan to round spray)
11	Fluid Adjustment (stepless regulation of fluid volume)
12	Anodized, forged aluminium gun body (ergonomic, good looking & durable, easy to clean)
13	125cc Acetal Cup (easy clean, anti-static)
14	Cup Lid with Drip Free Vent (avoid drips)
15	Air Valve (design offers low pull force & low pressure drop)
16	Gun acceptable for waterborne and solvent borne applications

**MATERIALS OF CONSTRUCTION**

Gun Body	Anodized aluminium
Air Cap	Nickel plated brass
Fluid Nozzle, Fluid Needle, Fluid Inlet, Trigger Stud	Stainless steel
Springs, Clips, Screws	Stainless steel
Seals, Gaskets	Solvent resistant
Trigger	Chrome plated steel
Air Inlet, Body Bushing, Spreader Valve Body, Air Valve Nut, Air Cap Retaining Ring, Knobs	Chrome plated brass
Air Valve Assembly	Stainless steel, HPDE

**SPECIFICATIONS & TECHNICAL DATA**

Air Supply Connection	Universal 1/4" BSP and 1/4" NPS male
Maximum Static Air Inlet Pressure	P1 = 175 psi (12 bar)
Nominal Gun Air Inlet Pressure for HVLP (HS1) and Trans-Tech® (TS1 & RS1) with gun triggered	29 psi (2.0 bar)
Fluid Supply Connection	7/16 – 14 UNC
Service Temperature	32 to 104°F (0 to 40°C)
Gun Weight (gun only) (with cup)	15.0 oz (425 g) 17.1 oz (485 g)

## SAFETY PRECAUTIONS

This manual contains information that is important for you to know and understand. This information relates to USER SAFETY and PREVENTING EQUIPMENT PROBLEMS. To help you recognize this information, we use the following symbols. Please pay particular attention to these sections.



**Important safety information – A hazard that may cause serious injury or loss of life.**

### CAUTION



**Important information that tells how to prevent damage to equipment, or how to avoid a situation that may cause minor injury.**

### NOTE

Information that you should pay special attention to.

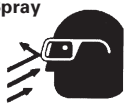

**The following hazards may occur during the normal use of this equipment.  
Please read the following chart before using this equipment.**

HAZARD	CAUSE	SAFEGUARDS
<p><b>Fire</b></p> 	<p>Solvent and coatings can be highly flammable or combustible especially when sprayed.</p>	<p>Adequate exhaust must be provided to keep air free of accumulations of flammable vapors.</p> <p>Smoking must never be allowed in the spray area.</p> <p>Fire extinguishing equipment must be present in the spray area.</p>
<p><b>Solvent Spray</b></p> 	<p>During use and while cleaning and flushing, solvents can be forcefully expelled from fluid and air passages. Some solvents can cause eye injury.</p>	<p>Wear eye protection.</p>
<p><b>Inhaling Toxic Substances</b></p> 	<p>Certain materials may be harmful if inhaled, or if there is contact with the skin.</p>	<p>Follow the requirements of the Material Safety Data Sheet supplied by your coating material manufacturer.</p> <p>Adequate exhaust must be provided to keep the air free of accumulations of toxic materials.</p> <p>Use a mask or respirator whenever there is a chance of inhaling sprayed materials. The mask must be compatible with the material being sprayed and its concentration. Equipment must be as prescribed by an industrial hygienist or safety expert, and be NIOSH approved.</p>
<p><b>Explosion Hazard - Incompatible Materials</b></p> 	<p>Halogenated hydrocarbon solvents - for example; methylene chloride and 1,1,1, - Trichloroethane are not chemically compatible with the aluminum that might be used in many system components. The chemical reaction caused by these solvents reacting with aluminum can become violent and lead to an equipment explosion.</p>	<p>Guns with stainless steel internal passageways may be used with these solvents. However, aluminum is widely used in other spray application equipment - such as material pumps, regulators, valves, and this gun and cup. Check all equipment items before use and make sure they can also be used safely with these solvents. Read the label or data sheet for the material you intend to spray. If in doubt as to whether or not a coating or cleaning material is compatible, contact your material supplier.</p>
<p><b>General Safety</b></p>	<p>Improper operation or maintenance of equipment.</p>	<p>Operators should be given adequate training in the safe use and maintenance of the equipment (in accordance with the requirements of NFPA-33, Chapter 15). Users must comply with all local and national codes of practice and insurance company requirements governing ventilation, fire precautions, operation, maintenance, and housekeeping. These are OSHA Sections 1910.94 and 1910.107 and NFPA-33.</p>
<p><b>Cumulative Trauma Disorders ("CTD's")</b></p> <p><b>CTD's, or musculoskeletal disorders, involve damage to the hands, wrists, elbows, shoulders, neck, and back. Carpal tunnel syndrome and tendonitis (such as tennis elbow or rotator cuff syndrome) are examples of CTD's.</b></p>	<p>Use of hand tools may cause cumulative trauma disorders ("CTD's").</p> <p>CTD's, when using hand tools, tend to affect the upper extremities. Factors which may increase the risk of developing a CTD include:</p> <ol style="list-style-type: none"> <li>1. High frequency of the activity.</li> <li>2. Excessive force, such as gripping, pinching, or pressing with the hands and fingers.</li> <li>3. Extreme or awkward finger, wrist, or arm positions.</li> <li>4. Excessive duration of the activity.</li> <li>5. Tool vibration.</li> <li>6. Repeated pressure on a body part.</li> <li>7. Working in cold temperatures.</li> </ol> <p>CTD's can also be caused by such activities as sewing, golf, tennis, and bowling, to name a few.</p>	<p>Pain, tingling, or numbness in the shoulder, forearm, wrist, hands, or fingers, especially during the night, may be early symptoms of a CTD. Do not ignore them. Should you experience any such symptoms, see a physician immediately. Other early symptoms may include vague discomfort in the hand, loss of manual dexterity, and nonspecific pain in the arm. Ignoring early symptoms and continued repetitive use of the arm, wrist, and hand can lead to serious disability. Risk is reduced by avoiding or lessening factors 1-7.</p>

**PARTS LIST**

REF. NO.	DESCRIPTION	PART NO.	QTY.
1	Air Cap Retaining Ring		1
2	Slip Ring		1
3	Air Cap		1
5	Retaining Ring Seal		1
6	Air Cap & Ring	See chart 1, p13	1
8	Fluid Nozzle	See chart 2, p13	1
9	Separator	COMM-2-K5	1
12*	Body Bushing Seal		1
13	Body Bushing		1
14	Body Bushing & Seal	SN-6-K	1
15	Fluid Needle	See chart 2, p13	1
16*	Needle Spring		1
17*	Needle Spring Pad		1
18	Fluid Adjusting Knob		1
19	Fluid Adjusting Knob, Spring & Pad Kit	PRO-3-K	1
20*	Retaining Clip		1
21	Spreader Valve Body		1
22*	Spreader Valve Seal		2
23	Spreader Valve Adjusting Knob		1
24*	Valve Pin		1
25	Spreader Valve Assembly	COMM-401-K	1
26*	Needle Packing		1
27*	Packing Spring		1
28	Packing Nut		1
29	Packing, Spring & Packing Nut Kit	SN-404-K	1
30	Air Valve Body		
31	Air Valve Cage		1

REF. NO.	DESCRIPTION	PART NO.	QTY.
32	Air Valve Poppet		1
33	Air Valve Spring		1
34	Air Valve Spring Pad		1
35	Air Valve Seal	SN-34-K5	1
36	Air Valve Assembly	SN-402-K	1
37*	Trigger Stud Screw (T20 TORX)		1
38	Trigger		1
39*	Trigger Stud		1
40	Trigger, Stud & Screw Kit	SN-42-K	1
41	Stud and Screw Kit	SN-405-K5	1
42	Air Inlet	SN-40-K	1
44	Airflow Valve	PRO-404-K	1
45	Circlip		1
51	Gravity Cup Kit	SRI-510	1
52	Drip Check Lid (kit of 5)	GFC-2-K5	1
56	Air Valve Service Tool		1
<b>SERVICE PARTS</b>			
Spray Gun Repair Kit (includes items marked *)		PRO-415-1	
Seal & Pin Kit, kit of 5 (items 20, 22 and 24)		GTI-428-K5	
For accessories, see page 16			



### INSTALLATION

For maximum transfer efficiency, do not use more pressure than is necessary to atomize the material being applied. **NOTE: when using the HS1, HVLP setup do not exceed 29.0 psi (2.0 bar) inlet pressure.**

1. Connect the gun to a clean, moisture and oil free air supply using a conductive hose.

#### NOTE

Install an air gauge at the gun handle. When gun is triggered on, adjust regulated pressure to 29.0 psi (2.0 bar). Do not use more pressure than is necessary to atomize the material being applied. Excess pressure will create additional overspray and reduce transfer efficiency.

2. Attach the gravity feed cup to the material inlet.

#### NOTE

Before using the gun, flush it with solvent to ensure that the fluid passages are clean.

### OPERATION

1. Mix coating material to manufacturer's instructions.
2. If required, fit the filter in the cup or use the funnel with a paper filter.
3. Fill the cup to no more than 1/2 inch from the top of the cup. **DO NOT OVERFILL.**
4. Attach Cup Lid.
5. Turn fluid adjusting knob (18) clockwise to prevent fluid needle movement.
6. Turn spreader valve adjusting knob (23) counter clockwise to fully open.
7. Adjust inlet air pressure to 29.0 psi (2.0 bar).
8. Turn fluid adjusting knob counter clockwise until first thread shows.
9. Test spray. If the finish is too dry, reduce airflow by reducing air inlet pressure.

10. If finish is too wet, reduce fluid flow by turning fluid adjusting knob (18) clockwise. If atomization is too coarse, increase inlet air pressure. If too fine, reduce inlet pressure.
11. The pattern size can be reduced by turning spreader valve knob (23) clockwise.
12. Hold gun perpendicular to surface being sprayed. Arcing or tilting may result in uneven coating.
13. The recommended spray distance is 3-6 in (75-150 mm).
14. Spray edges first. Overlap each stroke a minimum of 75%. Move gun at a constant speed.
15. Always turn off air supply and relieve pressure when gun is not in use.

### PREVENTIVE MAINTENANCE & CLEANING

To clean air cap and fluid nozzle, brush exterior with a stiff bristle brush. If necessary to clean cap holes, use a broom straw or toothpick if possible. If a wire or hard instrument is used, extreme care must be used to prevent scratching or burring of the holes which will cause a distorted spray pattern.

To clean fluid passages, remove excess material from cup, then flush with gun wash solution. Wipe the gun exterior with a dampened cloth. Never completely immerse in any solvent or cleaning solutions as this is detrimental to the lubricants and life of the spray gun.

#### NOTE

When replacing the fluid nozzle or fluid needle, replace both at the same time. Using worn parts can cause fluid leakage. See page 13, Chart 2. Also, replace the needle packing at this time. Torque the fluid nozzle to 70 in-lbs (8 Nm). Do not over tighten.

### CAUTION

To prevent damage to fluid nozzle (8) or fluid needle (15), be sure to either 1) pull the trigger and hold while tightening or loosening the fluid nozzle, or 2) remove fluid adjusting knob (18) to relieve spring pressure against needle collar.

### CAUTION

**IMPORTANT — the Gravity cup is made from special anti-static materials, but it still important to avoid generating static charges. The Cup must not be cleaned or rubbed with a dry cloth or paper. It is possible to generate a static charge by rubbing which, if discharged to an grounded object could create an incendive spark and cause solvent vapors to ignite. Only use a dampened cloth or antistatic wipes if manual cleaning is required within a hazardous area.**

## PARTS REPLACEMENT/MAINTENANCE

### AIR VALVE INSTRUCTIONS

#### Servicing Air Valve

Reasons to service air valve:

- A) Air valve not functioning correctly (may need cleaning).
- B) Routine maintenance.
- C) Air leaks (advise replacement, see p10)

1. Remove trigger using the tool supplied or TORX T20 key. (See fig 1 & 2)
2. Unscrew air valve using 14 mm spanner. (See fig 3)
3. Remove air valve by gripping stem. (See fig 4)
4. Remove spring with spring pad. (See fig 5)
5. DO NOT REMOVE REAR SEAL (35) FROM GUN BODY. (See fig 6)
6. DO NOT REMOVE PLASTIC CAGE FROM AIR VALVE BODY AS THIS MAY DAMAGE THE CAGE. (See fig 7)
7. CLEAN
  - a. Remove all paint build up. (See fig 8)
  - b. The 4 poppet holes must be clear. (See fig 9)
  - c. Stem must be free to float in poppet. (See fig 10)
  - d. Stem must slide through cage bore with slight resistance (due to seal).
  - e. Rear seal must look clean and in position in the bore. (See fig 6)
  - f. If any of the above cannot be rectified, replace the air valve (See Replacing Air Valve p10).
8. Replace spring ensuring the end with the plastic bearing pad goes in first. (See fig 5)
9. Insert air valve assembly into gun and carefully feed over the spring and through the rear seal. (See fig 11)
10. Tighten air valve assembly using fingers first, and then tighten with 14mm Spanner. (See figs 12 & 3)
11. Replace trigger. (See figs 2 & 1)
12. If there is an air leak through the gun, the air valve may need replacing (See Replacing Air Valve).

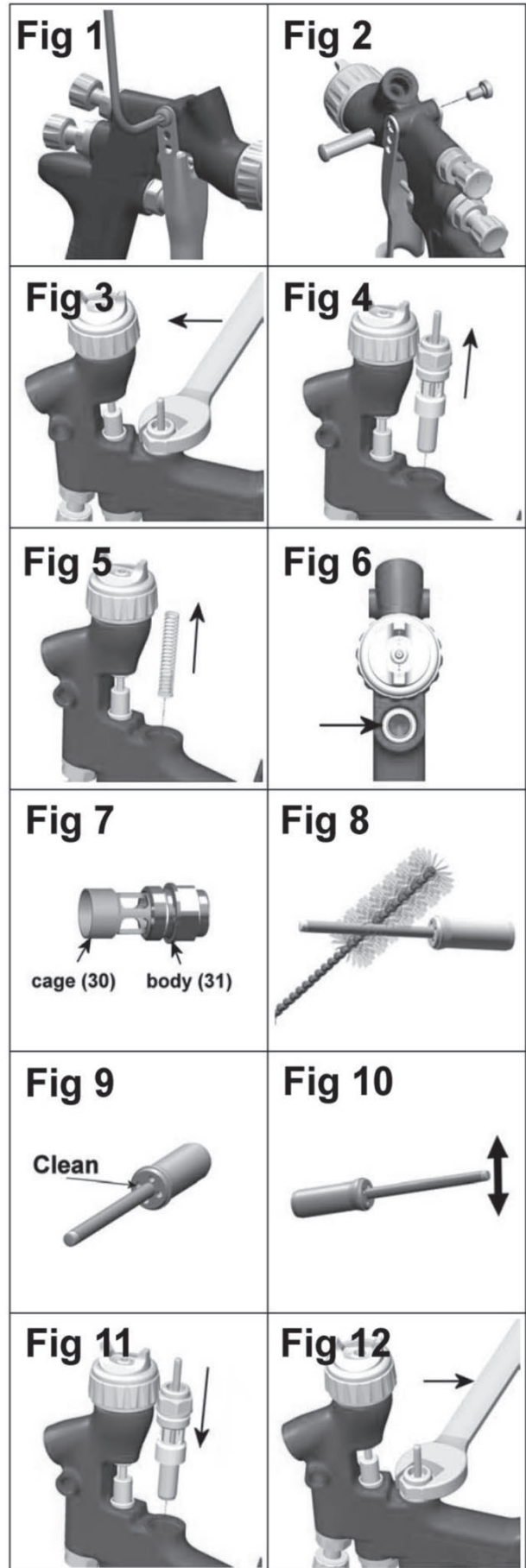

## PARTS REPLACEMENT/MAINTENANCE

### AIR VALVE INSTRUCTIONS

#### Replacing Air Valve

Reasons to replace air valve:

- A) Air leak through the gun.
- B) Air valve not operating correctly.

1. Remove trigger using TORX (T20) key provided in the kit. (See figs 13 & 14)
2. Unscrew air valve using 14 mm Spanner. (See fig 15)
3. Remove air valve by gripping the stem. (See fig 16)
4. Remove spring with spring pad. (See fig 17)
5. Hook out rear seal using Service Tool (56). (See figs 18 & 19)
6. Clean air valve bores in gun body with the brush supplied in the kit.
7. Place new rear seal onto Service tool (56); grooves must fit in service tool form. (See fig 20)
8. Push rear seal firmly into hole up to shoulder, using Service tool. (See figs 21 & 22)
9. Insert new spring, ensuring the end with the plastic bearing pad goes in first. (See fig 17)
10. Insert air valve assembly into gun and carefully feed over the spring and through the rear seal. (See fig 23)
11. Tighten air valve assembly using fingers first, then tighten with 14 mm Spanner. (See figs 24 & 15)
12. Replace trigger. (See figs 14 & 13)

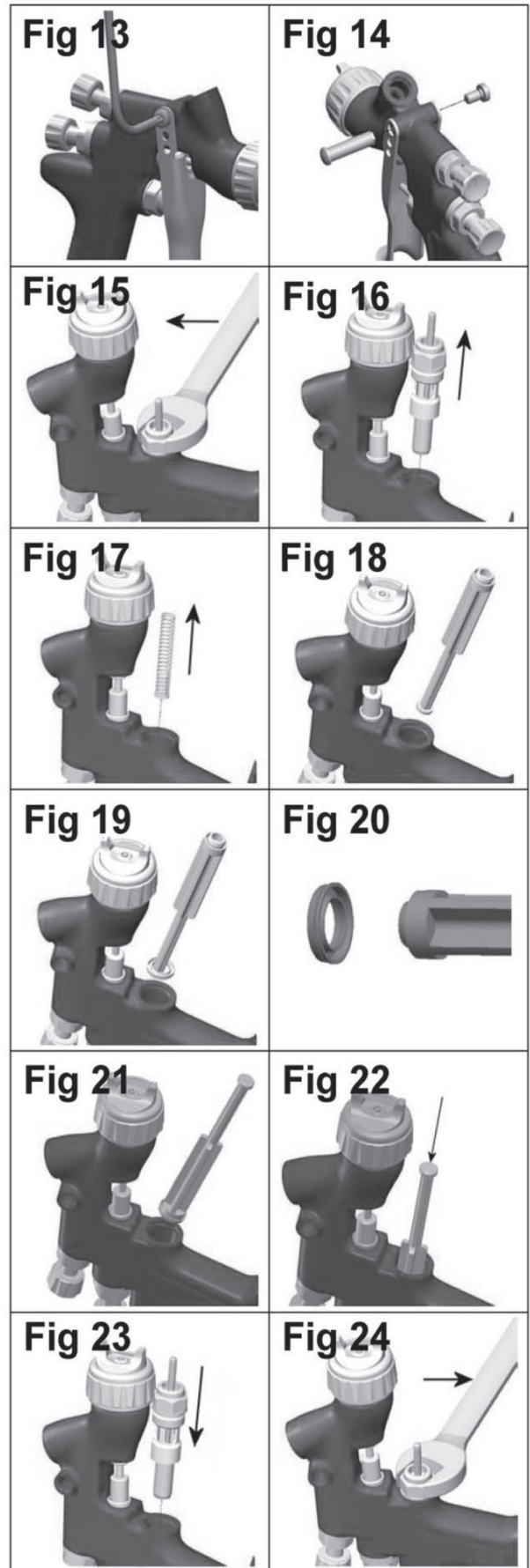

**PARTS REPLACEMENT/MAINTENANCE****NEEDLE PACKING INSTRUCTIONS****Replacing Needle Packing**

13. Remove trigger using TORX (T20) driver. (See figs 25 & 26)
14. Remove fluid adjusting knob and needle spring with spring pad from gun. (See figs 27 & 28)
15. Remove fluid needle from gun body. (See fig 29)
16. Loosen and remove packing nut using a straight blade screwdriver. (See figs 30 & 31)
17. Discard old packing and packing spring if replacing. Clean packing if reusing. Also clean packing spring and nut. (See fig 32).
18. Re-assemble the packing, (See fig 32). Assemble into gunbody by hand (see fig 33) and then tighten. (See figs 30 and 31)
19. Insert fluid needle all the way into gun body seating in fluid nozzle (See fig 34).
20. Insert needle spring, spring pad, and fluid adjusting knob. (See figs 28 & 27). Reinstall trigger. (See figs 25 & 26).
21. Trigger gun fully and screw in fluid adjusting knob until it stops. Back it off 3 turns and gun will have full needle travel.
22. Trigger gun several times to verify correct operation.

**SPREADER VALVE ASSEMBLY REPLACEMENT/MAINTENANCE**

The spreader valve assembly can be replaced if damaged. Remove using 14 mm Spanner (See figs 35 & 36). The internal seal can be replaced and is included in the Gun Rebuild Kit.

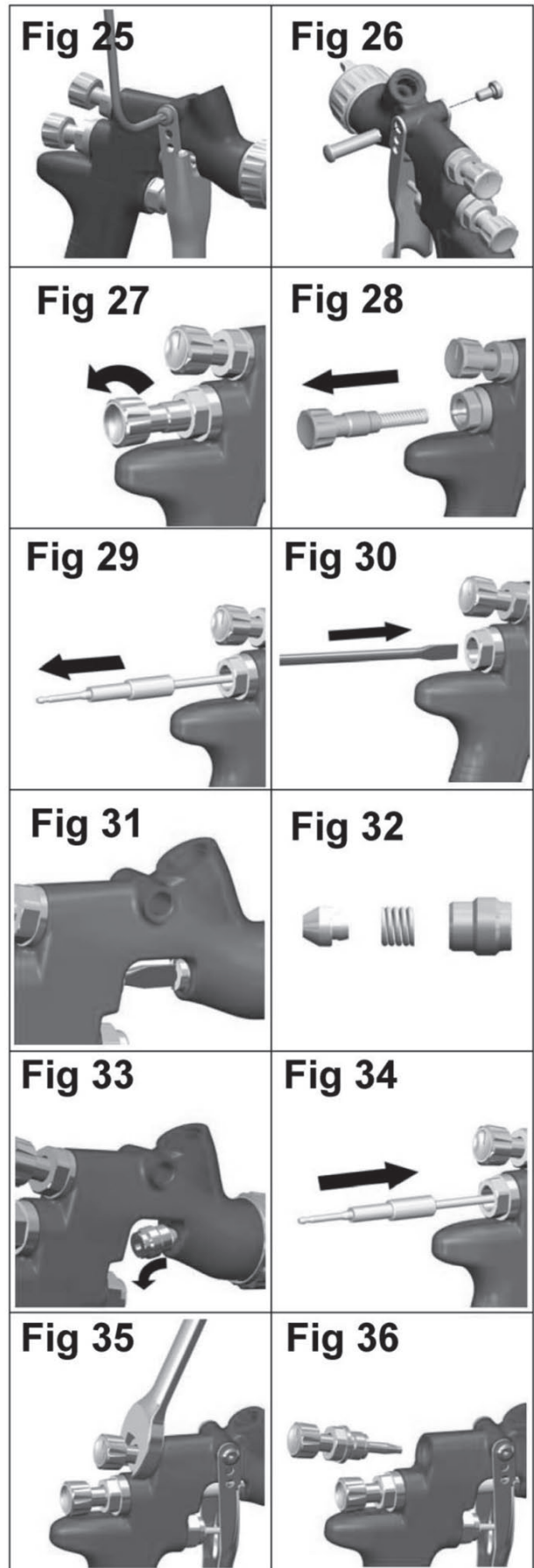

**PARTS REPLACEMENT/MAINTENANCE**

**SEPARATOR SEAL INSTRUCTIONS**

**Replacing Separator Seal**

1. Remove air cap and retaining ring. (See fig 37)
2. Remove fluid adjusting knob, spring, and spring pad. (See figs 38 & 39)
3. Remove fluid needle from gun body. (See fig 40)
4. Remove fluid nozzle using 8 mm Spanner. (See figs 41, & 42)
5. Remove Separator. (See fig 43).
6. Clean front of gun if required, using a soft brush, as well as the fluid nozzle, air cap, and retaining ring.
7. Place a new Separator Seal into the front of the gun, making sure the flat side of the seal is aligned with the flat in the gun. (See fig 44)
8. Fit Fluid Nozzle, Air Cap, and Retaining Ring. Torque the Fluid Nozzle to 70 in-lbs (8 Nm). Don't over torque the Fluid Nozzle. (See figs 45, 46, and 37)
9. Insert Fluid Needle all the way into the Gun Body, seating in the Fluid Nozzle. (See fig 47)
10. Reassemble Needle Spring, Spring Pad, and Fluid adjusting Knob. (See fig 47)
11. Trigger gun fully and screw in Fluid Adjusting Knob until it stops. Back it off 3 turns and gun will have full needle travel.
12. Trigger gun several times to verify correct operation. (see fig 48)

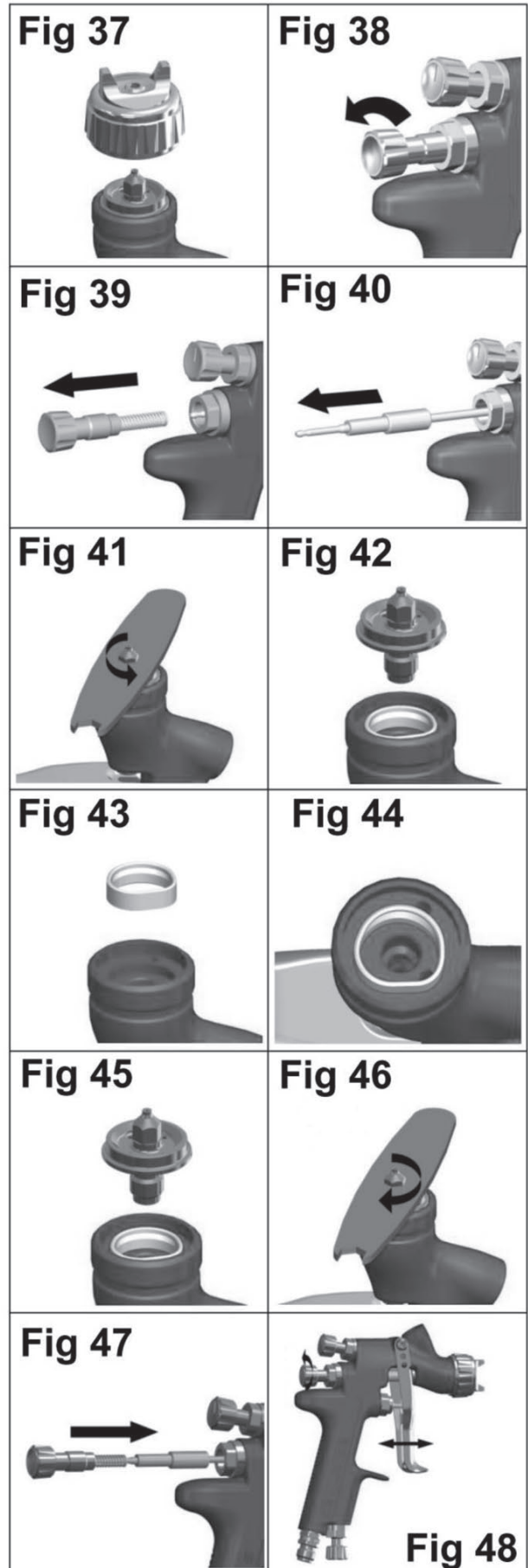

**PARTS REPLACEMENT/MAINTENANCE****CHART 1 – AIR CAPS**

<b>PART NO. FOR AIR CAP</b>	<b>TECHNOLOGY</b>	<b>MARKING ON AIR CAP</b>	<b>RECOMMENDED INLET PRESSURE</b>	<b>AIR FLOW (L/min)</b>
COMM-100-HS1	HVLP	HS1	29.0 psi (2.0 bar)	135
COMM-100-TS1	TRANS-TECH®	TS1	29.0 psi (2.0 bar)	100
COMM-100-RS1	TRANS-TECH®	RS1	14.0 psi (1.0 bar)	55

NOTE: When removing air cap from retaining ring, don't remove the Slip Ring (2) or Retaining Ring Seal (5) from the Retaining Ring. Damage to the parts may occur. Slip ring and Retaining Ring seal are not available as replacements. Simply wipe parts clean and reassemble with new or clean air cap.

**CHART 2 – FLUID NOZZLE RANGE & FLUID NEEDLE**

<b>PART NO. ON FLUID NOZZLE</b>	<b>PART NO. NEEDLE</b>
COMM-200-08	COMM-300-0810
COMM-200-10	
COMM-200-12	COMM-300-1214
COMM-200-14	

NOTE: When replacing the fluid nozzle or fluid needle, replace both at the same time. Torque to 70 in-lbs (8 Nm). Don't over tighten the fluid nozzle. Use 6mm Spanner supplied with the gun and check with a torque wrench.



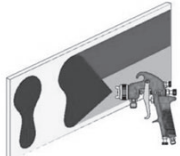
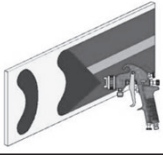
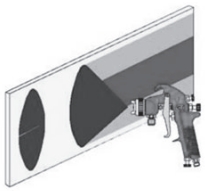
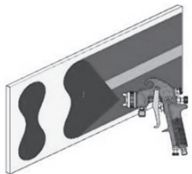
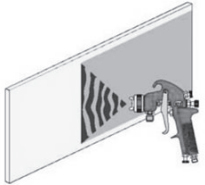

**TROUBLESHOOTING POSSIBLE PROBLEMS IN OPERATION**

CONDITION	CAUSE	CORRECTION
<p><b>Heavy top or bottom pattern</b></p>  <p><b>Heavy right or left side pattern</b></p> 	<p>Horn holes plugged.</p> <p>Obstruction on top or bottom of fluid nozzle.</p> <p>Cap and/or nozzle seat dirty.</p> <p>Left or right side horn holes plugged.</p> <p>Dirt on left or right side of fluid nozzle.</p>	<p>Clean. Ream with non-metallic point.</p> <p>Clean.</p> <p>Clean.</p> <p>Clean. Ream with non-metallic point.</p> <p>Clean.</p>
<p><b>Remedies for the top-heavy, bottom-heavy, right-heavy, and left-heavy patterns:</b></p> <p>1. Determine if the obstruction is on the air cap or the fluid nozzle. Do this by making a test spray pattern. Then, rotate the cap one-half turn and spray another pattern. If the defect is inverted, obstruction is on the air cap. Clean the air cap as previously instructed. Also check for dried paint just inside the cap center hole opening; remove by washing with solvent.</p> <p>2. If the defect is not inverted, it is on the fluid nozzle. Clean nozzle. If problem persists, renew nozzle.</p>		
<p><b>Heavy center pattern.</b></p> 	<p>Spreader adjustment valve set too low.</p> <p>Atomizing pressure too low.</p> <p>Material too thick.</p>	<p>Turn out counter clockwise to achieve correct pattern.</p> <p>Increase pressure.</p> <p>Thin to correct consistency.</p>
<p><b>Split spray pattern</b></p> 	<p>Air pressure too high.</p> <p>Fluid adjusting knob turned in too far.</p> <p>Spreader adjusting valve set too high.</p>	<p>Reduce at regulator or gun handle.</p> <p>Turn out counter clockwise to achieve correct pattern.</p> <p>Turn in clockwise to achieve correct pattern.</p>
<p><b>Jerky or fluttering spray</b></p> 	<p>Loose or damaged fluid nozzle/seat</p> <p>Loose or broken cup fluid nipple</p> <p>Material level too low</p> <p>Container tipped too far</p> <p>Obstruction in fluid passage</p> <p>Loose fluid needle packing nut</p> <p>Damaged fluid needle packing</p>	<p>Tighten or replace</p> <p>Tighten or replace cup</p> <p>Refill</p> <p>Hold more upright</p> <p>Back flush with solvent</p> <p>Tighten</p> <p>Replace</p>
<p><b>Paint bubbles in cup</b></p>	<p>Fluid nozzle not tight.</p>	<p>Fluid nozzle not tight. Tighten to 70 in-lbs (8 Nm).</p>

## TROUBLESHOOTING POSSIBLE PROBLEMS IN OPERATION

<b>Fluid leaking or dripping from cup lid</b>	Cup lid loose. Dirty cup or lid. Cracked cup or lid.	Push in or replace. Clean. Replace cup and lid.
<b>Starved spray pattern</b>	Inadequate material flow Blocked vent in Cup lid Low atomization air pressure	Wind fluid adjusting knob out or change to larger fluid nozzle size. Clean lid and unblock vent. Increase air pressure and rebalance gun.
<b>Excessive overspray</b>	Air pressure too high. Gun too far from work surface.	Reduce air pressure. Adjust to correct distance.
<b>Dry spray</b>	Air pressure too high. Gun too far from work surface. Gun motion too fast. Fluid flow too low.	Reduce air pressure. Adjust to correct distance. Slow down. Wind out needle adjusting screw or use larger nozzle size.
<b>Fluid leaking from packing nut</b>	Packing worn.	Replace.
<b>Fluid leaking or dripping from front of gun</b>	Fluid nozzle or fluid needle worn or damaged. Foreign matter in fluid nozzle. Fluid needle dirty or stuck in needle packing Wrong size fluid needle or fluid nozzle.	Replace fluid nozzle and fluid needle. Clean. Clean. Replace fluid nozzle and fluid needle.
<b>Fluid dripping or leaking from bottom of cup</b>	Cup loose on gun. Cup fluid inlet seat dirty.	Tighten. Clean.
<b>Runs and sags</b>	Too much material flow. Material too thin. Gun tilted on an angle, or gun motion too slow.	Turn fluid adjusting knob clockwise or switch to smaller fluid nozzle and fluid needle size. Mix correctly or apply light coats. Hold gun at right angle to work and adapt to correct gun technique.

**ACCESSORIES**

<p><b>72-2332 Swivel</b></p> 	<p><b>42884-214-K5 Cleaning Brush</b></p> 	<p><b>71-31101 ErgoFlex Hose with 1/4" Fittings</b></p> 	<p><b>SRI-478-K12 Disposable Cup Kit of 12</b></p> 	<p><b>DeKups Disposables</b></p> <p><b>DPC-602</b> 9 oz Disposable Cups</p> <p><b>DPC-607</b> 9 oz. Frames</p> <p><b>DPC-23</b> Disposable Cup Adapter</p>
--	---	---	---	--

**WARRANTY**

This product is covered by DeVilbiss' 1 Year Limited Warranty.

---

**DeVilbiss Worldwide Sales and Service Listing: [www.devilbiss.com](http://www.devilbiss.com)**

---

**North American Office**  
ITW Industrial Finishing  
195 Internationale Blvd.  
Glendale Heights, IL 60139  
630-237-5000  
[www.devilbiss.com](http://www.devilbiss.com)

Toll Free Customer Service  
and Technical Support  
800-992-4657

Toll Free Fax  
888-246-5732

